

REVISION HISTORY		
REV.	DESCRIPTION	DATE
03	REVISED PER LM14260	2016-01-26
A	INITIAL RELEASE PER LM14260	2016-02-04
B	REVISE PER LM14260	2016-04-26

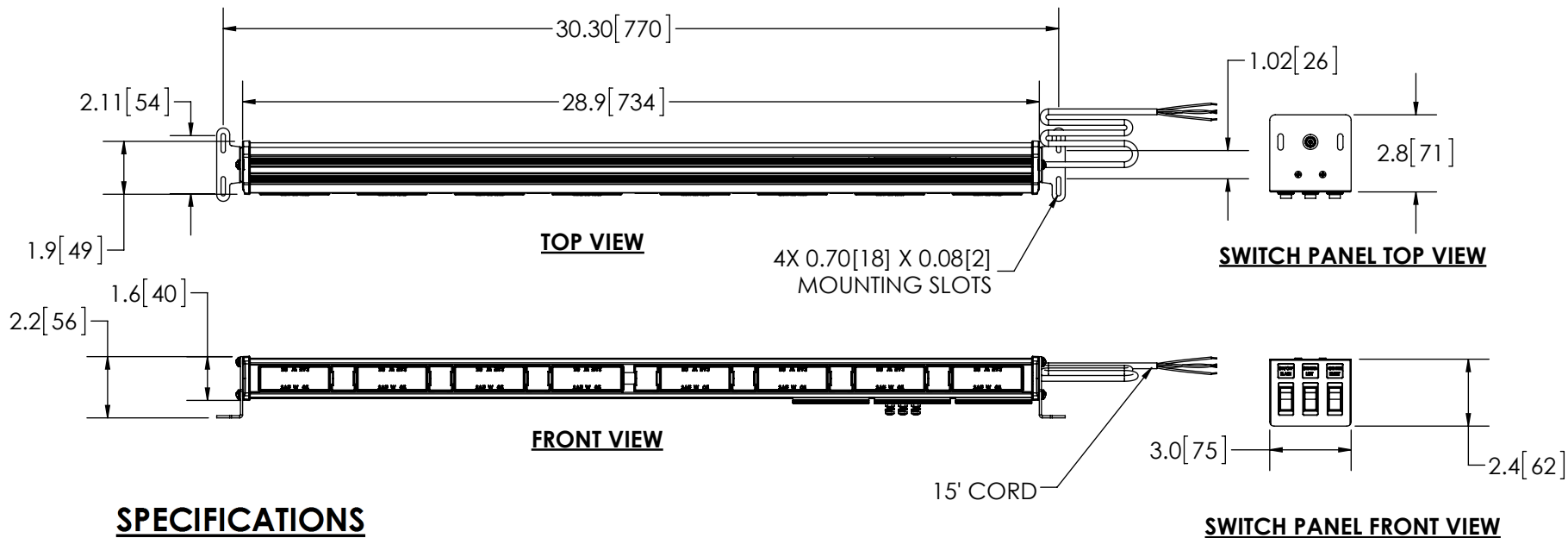

SPECIFICATIONS

- CERTIFICATIONS:** SAE J595 CLASS 1; YELLOW;
 Note: Unique components, accessories, and hardware kits are not typically included in the Product Certification Test Protocols. Unless otherwise Specified, the Product Certifications referred to herein are predicated upon the base product model configuration.
- FLASH MODE:** FLASH : ± 5 FLASHES PER MINUTE
 RIGHT SWEEP : ± 5 FLASHES PER MINUTE
 LEFT SWEEP : ± 5 FLASHES PER MINUTE
- VOLTAGE (NOMINAL):** 12 to 24 VDC
- VOLTAGE (EXTREME):** 11 to 30 VDC
- CURRENT (PEAK):** 4A (@ 12 VDC NOMINAL)
- POWER (MAXIMUM):** 24.W (@ 12 VDC NOMINAL)
- TEMPERATURE RANGE:** -22°F (-30°C) TO 122°F (50°C)
- CONNECTION:** 2 - 18 AWG WIRES
- MOUNTING:** BRACKET MOUNT
- BASE MATERIAL:** ALUMINUM
- LENS MATERIAL:** POLYCARBONATE
- PRODUCT WEIGHT:** 4.3 LBS (1.94 Kg)

DISCLAIMER

DIMENSIONS, ILLUSTRATIONS, SPECIFICATIONS, AND CERTIFICATIONS CONTAINED IN THIS DOCUMENT ARE TYPICAL OF THE ACTUAL PRODUCT AND ARE SUBJECT TO CHANGE. ECCO ENGINEERING DOES NOT MAINTAIN FORMAL DESIGN CONTROL OF THIS PRODUCT.

MOUNTING DISCLAIMER

MOUNTING MEASUREMENT IS FOR REFERENCE ONLY. MEASURE BEFORE DRILLING.

- NOTES:**
 1. DIMENSIONS IN INCHES [MILLIMETERS (FOR REFERENCE)]

SCALE 1:6		APPROVALS	DATE	ECCO® www.eccolink.com	
CAD GENERATED DRAWING DO NOT MANUALLY UPDATE. MODEL REFERENCED:01		DRAWN BY ABD	2016-04-19	Americas (800) 635-5900 Europe +44 (0)113 237 5340 Asia Pacific +61 (0)3 63322444	
		CHECKED ABB	2016-04-20		
TOLERANCES ARE IN INCHES AND MILLIMETERS TOLERANCES UNLESS OTHERWISE STATED ARE:		MECH. ENG. JLA	2016-04-19	XT3 SERIES ARROWSTIK KIT 30"	
		ELEC. ENG. TJT	2016-04-25		
MILLIMETERS DECIMALS XX. ± 1.0mm XX.X ± 0.5mm		TEST ENG. JRT	2016-04-20	CUSTOMER PART NO. 37038AS	
		SALES. GLB	2016-04-25		
THIRD ANGLE PROJECTION				SIZE: A	DWG. NO. 37038AS
		Electronically Controlled Use Latest Copy		SHEET 1 OF 1	Project: LM14260
				Date Created: 2015-12-10	REV. B

THIS DRAWING AND THE DESIGN IT DISCLOSES ARE THE PRIVATE PROPERTY OF ESG AND IS ISSUED IN CONFIDENCE FOR ENGINEERING INFORMATION ONLY. THE DRAWING AND / OR DESIGN MAY NOT BE USED, COPIED, REPRODUCED, OR OTHERWISE DISCLOSED IN PART OR AS A WHOLE TO OUTSIDERS OR USED FOR ANY OTHER PURPOSE WITHOUT THE PRIOR WRITTEN CONSENT OF ESG. THE DRAWING IS SUBJECT TO RECALL AT ANY TIME. YOUR POSSESSION OF THIS DOCUMENT CONSTITUTES ACCEPTANCE OF THESE TERMS. © 2015 ECCO