

3-16 AWG WIRES
 RED: POSITIVE(+)
 BLK: NEGATIVE(-)
 WHT: SINGLE/DUAL

REVISION HISTORY		
REV.	DESCRIPTION	DATE
C	CORRECTED SPELLING ERRORS ON NOTES PER CR# 1138	2002-06-18
D	CORRECTED SPECIFICATIONS PER CR# 1636	2004-10-19
E	REVISED PER EC3010	2010-11-29

LENS CHART	
PRODUCT P/N	LENS COLOR
6530A	AMBER
6530B	BLUE
6530C	CLEAR
6530G	GREEN
6530R	RED

SPECIFICATIONS

- CERTIFICATIONS: **CE**; AMECA/SAE J1318 (MAY 1998), CLASS 2, YELLOW (AMBER) BLUE WHITE (CLEAR) RED COLORS;
 Note: Unique components, accessories, and hardware kits are not typically Included in the Product Certification Test Protocols. Unless otherwise Specified, the Product Certifications referred to herein are predicated upon the base product model configuration.
- FLASH MODE: SINGLE : 80 ± 5 FLASHES PER MINUTE
 DOUBLE : 80 ± 5 FLASHES PER MINUTE
 : ± 5 FLASHES PER MINUTE
- VOLTAGE (NOMINAL): 12 to 48 VDC
- VOLTAGE (EXTREME): 9.0 to 56.0 VDC
- CURRENT (PEAK): 2.160A (@ 12 VDC NOMINAL)
- POWER (MAXIMUM): 27.648W (@ 12 VDC NOMINAL)
- TEMPERATURE RANGE: -22°F (-30°C) TO 122°F (50°C)
- CONNECTION: 3-16 AWG. WIRES
- MOUNTING: "J" BOLT
- BASE MATERIAL: ALUMINUM
- LENS MATERIAL: POLYCARBONATE
- PRODUCT WEIGHT: 2.4 LBS (1.08 Kg)

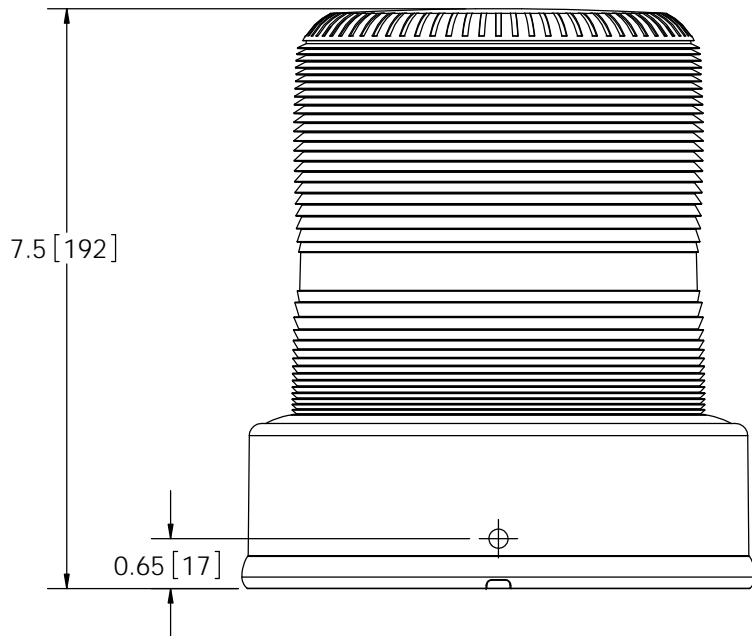

SCALE 1:2.5			APPROVALS	DATE
CAD GENERATED DRAWING DO NOT MANUALLY UPDATE. MODEL REFERENCED:B			DRAWN BY BND	
			CHECKED	
TOLERANCES ARE IN INCHES, AND MILLIMETERS TOLERANCES ARE:			MECH. ENG.	
			ELEC. ENG.	
MILLIMETERS DECIMALS XX ± 1.0mm XX.X ± 0.5mm	INCHES DECIMALS XX ± 0.1 XXX ± 0.04 XXXX ± 0.02	ANGLES ± 0.5° FRACTIONS ± 1/64	TEST ENG.	
			SALES.	

ECCO® Electronic Controls Co.
 833 West Diamond Street, Boise, ID 83705
 800-635-5900
 www.eccolink.com

STROBE, 360*, J-BOLT, AMBER, 12-48VDC, 5/7J

CUSTOMER PART NO. SEE CHART		PRODUCT SERIES: 6500	
SIZE: A	DWG. NO. 6530X	REV. E	
SHEET 1 OF 1	Project: 99010	Date Created: 1999-09-30	

NOTES:
 1. DIMENSIONS IN INCHES[MILLIMETERS (FOR REFERENCE)]

NON DISCLOSURE AGREEMENT

THIS DRAWING AND THE DESIGN IT DISCLOSES ARE THE PRIVATE PROPERTY OF ECCO AND IS ISSUED IN CONFIDENCE FOR ENGINEERING INFORMATION ONLY. THE DRAWING AND / OR DESIGN MAY NOT BE USED, COPIED, REPRODUCED, OR OTHERWISE DISCLOSED IN PART OR AS A WHOLE TO OUTSIDERS OR USED FOR ANY OTHER PURPOSE WITHOUT THE PRIOR WRITTEN CONSENT OF ECCO. THE DRAWING IS SUBJECT TO RECALL AT ANY TIME. YOUR POSSESSION OF THIS DOCUMENT CONSTITUTES ACCEPTANCE OF THESE TERMS. © 2004 ECCO

