



# Installation and Operation Instructions

## 5300 series Minibar

The ECCO 5300 series is a powerful, mid-sized, permanent, magnet, or vacuum-magnet mounted Minibar. The low profile and ease of installation make it one of the most versatile warning Minibars on the market today.



**IMPORTANT!** Read all instructions before installing and using. Installer: This manual must be delivered to the end user.

### **WARNING!**

Failure to install or use this product according to manufacturer's recommendations may result in property damage, serious bodily/personal injury, and/or death to you and those you are seeking to protect!



**Do not install and/or operate this safety product unless you have read and understand the safety information contained in this manual.**

1. Proper installation combined with operator training in the use, care, and maintenance of emergency warning devices are essential to ensure the safety of you and those you are trying to protect.
2. Exercise caution when working with live electrical connections.
3. This product must be properly grounded. Inadequate grounding and/or shorting of electrical connections can cause high current arcing, which can cause personal injury and/or severe vehicle damage, including fire.
4. Proper placement and installation are vital to the performance of this warning device. Install this product so that output performance of the system is maximized and the controls are placed within convenient reach of the operator so that s/he can operate the system without losing eye contact with the roadway.
5. It is the responsibility of the vehicle operator to ensure during use that all features of this product work correctly. In use, the vehicle operator should ensure the projection of the warning signal is not blocked by vehicle components (i.e., open trunks or compartment doors), people, vehicles, or other obstructions.
6. The use of this or any other warning device does not ensure all drivers can or will observe or react to a warning signal. Never take the right-of-way for granted. It is your responsibility to be sure you can proceed safely before entering an intersection, driving against traffic, responding at a high rate of speed, walking on or around traffic lanes.
7. This equipment is intended for use by authorized personnel only. The user is responsible for understanding and obeying all laws regarding warning signal devices. Therefore, the user should check all applicable city, state, and federal laws and regulations. The manufacturer assumes no liability for any loss resulting from the use of this warning device.

## Specifications:

Size:	15.5" x 8.2" x 5.7"	
Weight:	Permanent Mount:	3.5 lb.
	Magnet Mount:	5.0 lb.
	Vacuum-Magnet Mount:	5.7 lb.
Voltage:	Model 5315:	12 VDC systems
	Model 5325:	24 VDC systems
Current draw:	8.6 Amps avg. @ 12.8 VDC	
	3.6 Amps avg. @ 25.6 VDC	
Flashes:	300 flashes/min. nominal	
Bulb:	50 Watt, SC bayonet, halogen	

## Unpacking:

Carefully remove the minibar and place it on a flat surface. Examine the unit for transit damage, broken lamps, etc.

## Installation & Mounting:

### Permanent Mounting:

Select the mounting location for the minibar on a flat, smooth surface. If the minibar is to be mounted on a curved surface, such as on the roof of the vehicle, choose a placement with the least amount of curvature. The mounting location for the minibar should be chosen such that there is maximum visibility to the oncoming traffic.

**Caution:** When drilling into any vehicle surface, make sure the area is free from any electrical wires, fuel lines, vehicle upholstery, etc. that could be damaged

Use the following instructions for mounting.

1. Using the holes in the base, mark the locations for the mounting holes. Drill the mounting holes using a 7/32" drill.
2. Drill a 3/8" hole for the minibar's power supply wire. The hole should be underneath where the minibar will be mounted. Place the supplied grommet in the hole, to protect the wires from the sharp edges of the hole.
3. Place the four (4) mounting bolts in the bottom of the base as shown in Figure 1. The base has a mechanism to hold the bolts in place for installation.
4. Mount the minibar, with the bolts going through the holes drilled in step 1, routing the wire through the grommet installed in step 2. See the Wiring section of this manual for further wiring instructions. Install washers and nuts, and secure the unit.

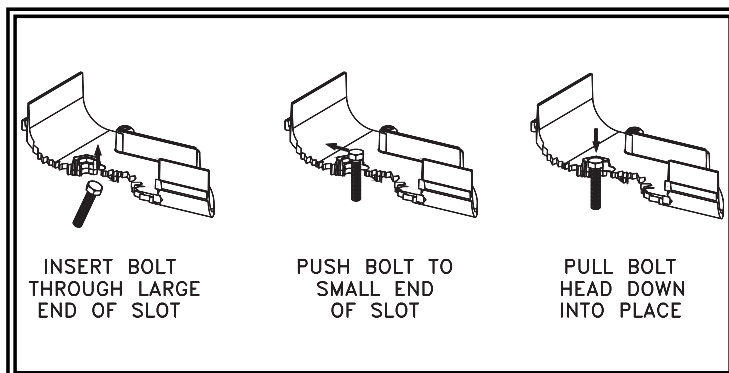

FIGURE 1

## Vacuum-Magnet Mounting:

The vacuum-magnet mount feature includes two (2) suction cups on the bottom of the minibar, with a magnet inside each of the suction cups, for a secure, temporary mount. The minibar should be placed in the center or the roof where the least amount of curvature occurs. Before installing, make sure there is no debris on the bottom of the minibar or on the roof of the vehicle, which could reduce the holding power of the suction cups and magnets. Place and remove the minibar without sliding to avoid scratching the paint on the vehicle. After placement, the minibar should adhere firmly to the surface. If the unit slides or moves easily, a proper installation has not been obtained. To remove unit from vehicle, lift each tab to release the airlock (See Figure 2). To protect the rubber cushion/magnet assembly, return minibar to the box when not in use. Do not attempt to attach to ice covered surface.



### WARNING!

Maximum recommended vehicle speed for safe operation using the Vacuum Mount model is 65 mph (104 km/h), when fitted to the center of a vehicle roof of steel construction. Higher speeds could cause the mount to fail, resulting in the minibar flying off of the vehicle, which could cause damage to other vehicles, and injury or death to the passengers. The vacuum-magnet mount is not intended as a permanent mounting for the minibar. The vacuum-magnet mount unit must be mounted on a flat smooth magnetic surface (i.e. no fiberglass, ribbed style roofs, etc.). Ensure that the magnet is kept clean.

## Magnet Mounting:

The magnet mount feature includes four (4) magnets on the bottom of the minibar, for a secure, temporary mount. There are four (4) adhesive disks included, which should be placed on the bottom of each magnet to prevent scratching the vehicle finish upon installation. The minibar should be placed in the center of the roof where the least amount of curvature occurs. Before installing, make sure there is no debris on the bottom of the magnets or on the roof of the vehicle, which could reduce the holding power of the magnets. Place and remove the minibar without sliding. After placement, the minibar should adhere firmly to the surface. If the unit slides or moves easily, a proper installation has not been obtained. To protect the minibar assembly, return it to the box when not in use. Do not attempt to attach to ice covered surface.

The magnet mount is not recommended for use on a moving vehicle, nor is it intended as a permanent mount for the minibar. Long duration usage of the magnet in the presence of moisture will cause the steel to rust.

## Wiring Instructions:

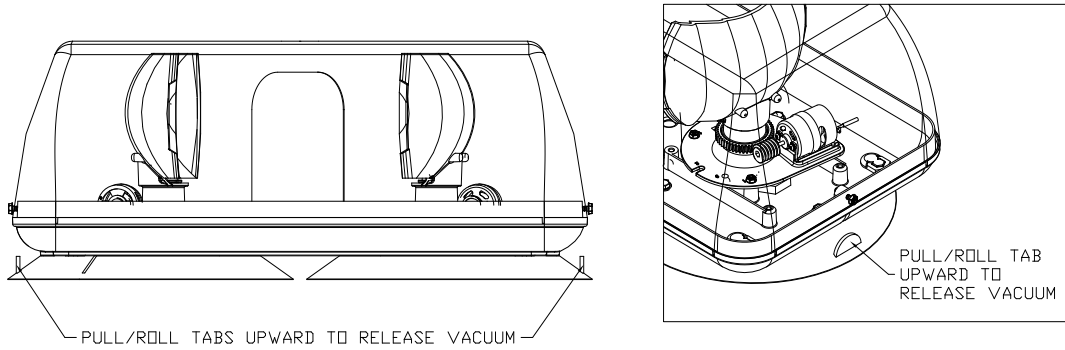

FIGURE 2



### WARNING!

Failure to follow these instructions can result in fire or injury from excessive heat build up.

Operator is responsible for ensuring cigarette adapter fits correctly into cigarette/auxiliary outlet used.

For proper operation, verify cigarette/auxiliary outlet circuit is rated to supply, a minimum of 10 amps. (See specifications section for rated current in amperes).

Do not exceed the current rating for the cigarette lighter power outlet recommended by vehicle manufacturer.

Keep cigarette lighter adapter, and outlet, clean and free of debris.

Do not use the cigarette lighter adapter when wet.

Insert cigarette lighter adapter fully into the outlet for proper connection.

Grasp cigarette lighter adapter, NOT cord, to remove from outlet.

Remove cigarette lighter adapter completely from outlet when light is not in use.

### Notes:

1. Larger wires and tight connections will provide longer service life for components. For high current wires it is highly recommended that terminal blocks or soldered connections be used with shrink tubing to protect the connections. Do not use insulation displacement connectors (e.g., 3M Scotchlock type connectors).
2. Route wiring using grommets and sealant when passing through compartment walls. Minimize the number of splices to reduce voltage drop. High ambient temperatures (e.g., under-hood) will significantly reduce the current carrying capacity of wires, fuses, and circuit breakers. All wiring should conform to the minimum wire size and other recommendations of the manufacturer and be protected from moving parts and hot surfaces. Looms, grommets, cable ties, and similar installation hardware should be used to anchor and protect all wiring.
3. Fuses or circuit breakers should be located as close to the power takeoff points as possible and properly sized to protect the wiring and devices.
4. Particular attention should be paid to the location and method of making electrical connections and splices to protect these points from corrosion and loss of conductivity.
5. Ground termination should only be made to substantial chassis components, preferably directly to the vehicle battery.
6. Circuit breakers are very sensitive to high temperatures and will "false trip" when mounted in hot environments or operated close to their capacity.

**Important!** Disable power before wiring up the minibar.

The 5300 series minibar is designed to operate on a 12 or 24 VDC negative ground system depending on the model. Use 16 AWG (UL 1015) or larger wires. If the wire is to be exposed to a high temperature environment, use 16 AWG (UL 3265 grade min.) type wire. Connect the black lead to the vehicle chassis, or preferably the negative terminal of the battery. Bring the red lead to the user supplied control switch, and then to the battery or to the battery side of the starter solenoid or alternator. Install a 12 Amp 3AG SLO-BLO fuse to protect the vehicle's wiring system against shorts (See Figure 3). The motor will rotate in a clockwise direction (when looking down on the unit from above).

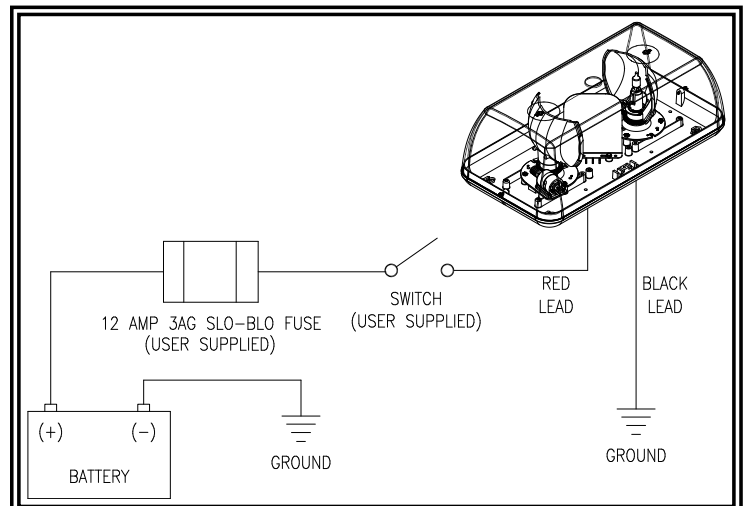

FIGURE 3

**Maintenance:**

Do not oil or grease this unit. It is constructed with permanently lubricated bearings and plastic gears, which do not need lubrication. Clean the lens and base with soap and water, or a lens polish using a soft cloth.

**Bulb Replacement:**

1. Remove the two (2) lens screws at either end of the base, and remove the lens.
2. Remove and replace the bulb, ECCO P/N R5012BH for 12 volt units, and R5024BH for 24 volt units. **Do Not touch the glass portion of the bulb.** Use clean gloves, replacement bulb bag, finger cots, etc., to prevent hand oil from contaminating the bulb, causing failure.
3. Replace the lens.



**WARNING!**

Bulbs are extremely hot! Allow to cool completely before attempting to remove. Gloves and eye protection should be worn when handling halogen bulbs as they are pressurized and accidental breakage can result in flying glass.

**Note:** Operating the vehicle without the lens installed on this product will result in damage that will not be covered under warranty.

**Trouble Shooting:**

Problem	Probable Cause	Suggested Remedy
Unit does not function when turned on	Poor ground or power connection	Check connections at the battery and the unit and repair
	Fuse Blown	Check fuse, replace if necessary
	No power / improper power	Verify that 12 VDC is reaching unit (12 V version only)
	Unit has been damaged	Return to ECCO
Rotator does not turn but bulb functions	Open circuit in motor wiring of rotator	Repair wiring
	Unit has been damaged	Replace rotator assembly or return to ECCO
Rotator turns but bulb does not function	Bulb has burned out	Replace bulb
	Open circuit in bulb wiring of rotator	Check for loose connection or damaged wires between motor and bulb assembly (2 wires)
	Unit has been damaged	Return to ECCO

**Replacement Parts/Accessories(refer to figure 4:**

Ref. No.	Description	Part No.
1	Replacement Lens, Amber	R5300LA
2	Replacement Lens, Blue	R5300LB
3	Replacement Lens, Clear	R5300LC
4	Replacement Lens, Green	R5300LG
5	Replacement Lens, Red	R5300LR
6	Motor Gear Assembly, 12 VDC, 100 FPM (2 assemblies required per unit)	R5015MGA
7	Motor Gear Assembly, 12 VDC, 200 FPM (2 assemblies required per unit)	R5017MGA
8	Motor Gear Assembly, 24 VDC, 100 FPM (2 assemblies required per unit)	R5025MGA
9	50 Watt Halogen Bulb, 12 VDC (2 bulbs required per unit)	R5012BH
10	50 Watt Halogen Bulb, 24 VDC (2 bulbs required per unit)	R5024BH
11	Vacuum-Magnet Mount Kit (includes hardware & coil cord)	A5300VMK
12	Magnetic Mount Kit (includes hardware & coil cord)	A5300MK
13	Vibration Dampening Kit	A6600VDK
14	Accessory, Filter, Amber (not shown)	A5000FA
15	Accessory, Filter, Blue (not shown)	A5000FB
16	Accessory, Filter, Red (not shown)	A5000FR

Exploded View: (Items not shown to scale)

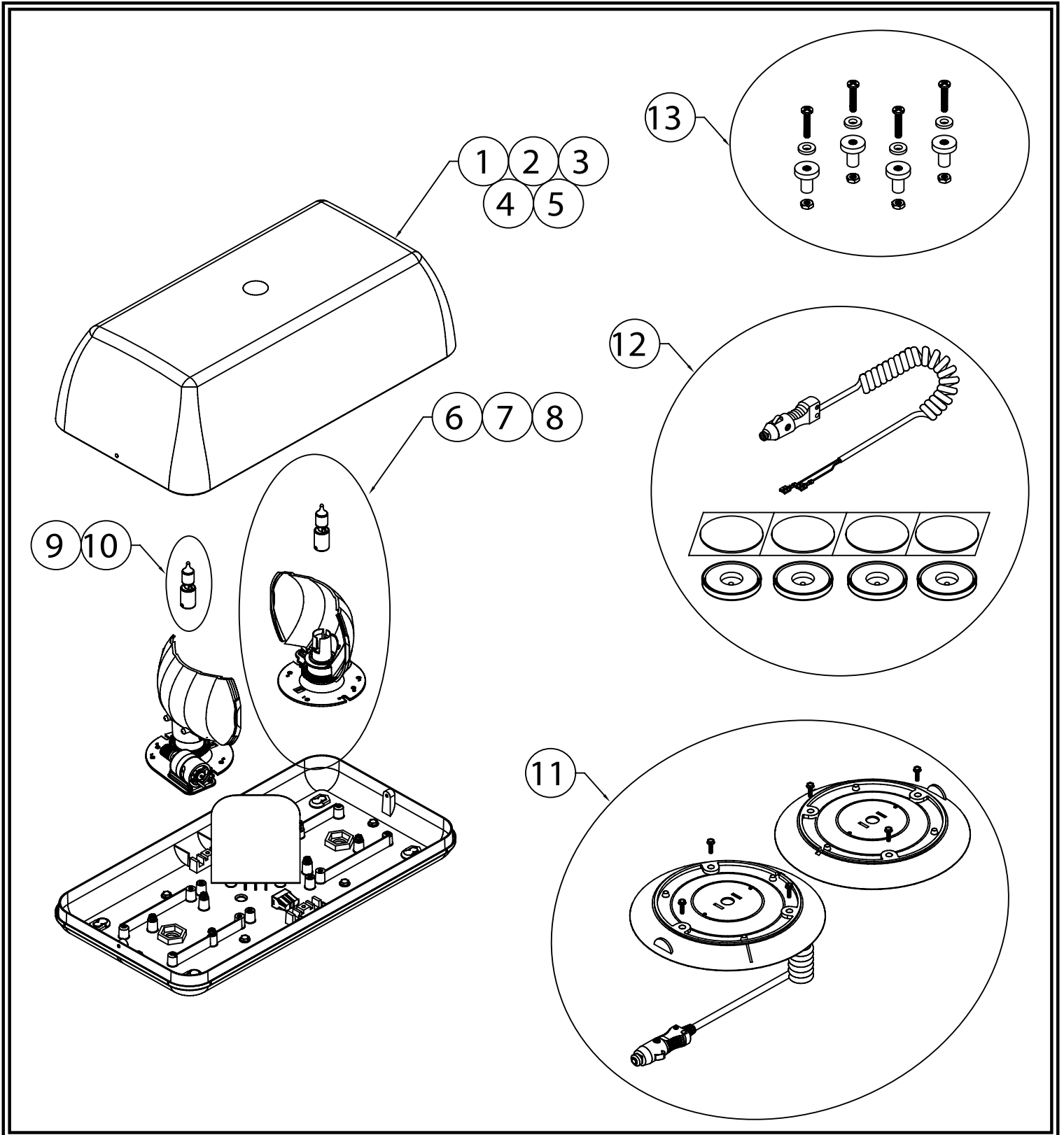

FIGURE 4

## **Manufacturer Limited Warranty and Limitation of Liability:**

Manufacturer warrants that on the date of purchase this product will conform to Manufacturer's specifications for this product (which are available from the Manufacturer upon request), and Manufacturer further warrants that this product is free from defects in materials and workmanship. This Limited Warranty extends for twenty-four (24) months (90 days for the bulb) from the date of purchase. Other warranties may apply, call Manufacturer for details. Manufacturer will, at its discretion, repair or replace any product found by the Manufacturer to be defective and subject to this Limited Warranty.

DAMAGE TO PARTS OR PRODUCTS RESULTING FROM TAMPERING, ACCIDENT, ABUSE, MISUSE, NEGLIGENCE, UNAPPROVED MODIFICATIONS, FIRE OR OTHER HAZARD; IMPROPER INSTALLATION OR OPERATION; OR NOT BEING MAINTAINED IN ACCORDANCE WITH THE MAINTENANCE PROCEDURES SET FORTH IN MANUFACTURER'S INSTALLATION AND OPERATING INSTRUCTIONS VOIDS THIS LIMITED WARRANTY.

ORAL STATEMENTS OR REPRESENTATIONS ABOUT THE PRODUCT WHICH MAY HAVE BEEN MADE BY SALESPEOPLE, DEALERS, AGENTS OR OTHER MANUFACTURER'S REPRESENTATIVES DO NOT CONSTITUTE WARRANTIES. THIS LIMITED WARRANTY MAY NOT BE AMENDED, MODIFIED, OR ENLARGED EXCEPT BY A WRITTEN AGREEMENT SIGNED BY AN AUTHORIZED OFFICIAL OF MANUFACTURER WHICH EXPRESSLY REFERS TO THIS LIMITED WARRANTY.

### **Exclusion of Other Warranties:**

MANUFACTURER MAKES NO OTHER WARRANTIES, EXPRESS OR IMPLIED. THE IMPLIED WARRANTIES FOR MERCHANTABILITY OR FITNESS FOR A PARTICULAR PURPOSE ARE HEREBY EXCLUDED AND SHALL NOT APPLY TO THE PRODUCT. BUYER'S SOLE AND EXCLUSIVE REMEDY IN CONTRACT, TORT, OR UNDER ANY OTHER THEORY AGAINST MANUFACTURER REGARDING THE PRODUCT AND ITS USE SHALL BE THE REPLACEMENT OR REPAIR OF THE PRODUCT AS DESCRIBED ABOVE.

### **Limitation of Liability:**

IN THE EVENT OF LIABILITY FOR DAMAGES ARISING OUT OF THIS LIMITED WARRANTY OR ANY OTHER CLAIM RELATED TO THE MANUFACTURER'S PRODUCTS, MANUFACTURER'S LIABILITY FOR DAMAGES SHALL BE LIMITED TO THE AMOUNT PAID FOR THE PRODUCT AT THE TIME OF THE ORIGINAL PURCHASE. IN NO EVENT SHALL MANUFACTURER BE LIABLE FOR LOST PROFITS, THE COST OF SUBSTITUTE EQUIPMENT OR LABOR, PROPERTY DAMAGE, OR OTHER SPECIAL, CONSEQUENTIAL, OR INCIDENTAL DAMAGES BASED UPON ANY CLAIM FOR BREACH OF CONTRACT, IMPROPER INSTALLATION, NEGLIGENCE, OR OTHER CLAIM, EVEN IF MANUFACTURER OR A MANUFACTURER'S REPRESENTATIVE HAS BEEN ADVISED OF THE POSSIBILITY OF SUCH DAMAGES. MANUFACTURER SHALL HAVE NO FURTHER OBLIGATION OR LIABILITY WITH RESPECT TO THE PRODUCT OR ITS SALE, OPERATION AND USE, AND MANUFACTURER NEITHER ASSUMES NOR AUTHORIZES THE ASSUMPTION OF ANY OTHER OBLIGATION OR LIABILITY IN CONNECTION WITH SUCH PRODUCT.

This Limited Warranty defines specific legal rights. You may have other legal rights which vary from state to state. Some states do not allow the exclusion or limitation of incidental or consequential damages.



833 West Diamond St  
Boise, Idaho 83705

**Customer Service**

USA 800-635-5900

UK +44 (0)113 237 5340

AUS +61 (0)3 63322444

[www.eccogroup.com](http://www.eccogroup.com)