



ECCO[®]

Installation and Operation Instructions REMOTE SPOTLIGHT

IMPORTANT! Read all instructions before installing and using. Installer: This manual must be delivered to the end user. ECCO is not responsible for the misuse of products by un-authorized personnel.



WARNING!

Failure to install or use this product according to manufacturer's recommendations may result in property damage, serious bodily/personal injury, and/or death to you and those you are seeking to protect! Check wattage before installing light to avoid possible equipment damage.



Do not install and/or operate this safety product unless you have read and understand the safety information contained in this manual.

1. Proper installation combined with operator training in the use, care, and maintenance of emergency warning devices are essential to ensure the safety of you and those you are trying to protect.
2. Exercise caution when working with live electrical connections.
3. This product must be properly grounded. Inadequate grounding and/or shorting of electrical connections can cause high current arcing, which can cause personal injury and/or severe vehicle damage, including fire.
4. Proper placement and installation are vital to the performance of this warning device. Install this product so that output performance of the system is maximized and the controls are placed within convenient reach of the operator so that s/he can operate the system without losing eye contact with the roadway.
5. Do not install this product or route any wires in the deployment area of an air bag. Equipment mounted or located in an air bag deployment area may reduce the effectiveness of the air bag or become a projectile that could cause serious personal injury or death. Refer to the vehicle owner's manual for the air bag deployment area. It is the responsibility of the user/operator to determine a suitable mounting location ensuring the safety of all passengers inside the vehicle particularly avoiding areas of potential head impact.
6. It is the responsibility of the vehicle operator to ensure during use that all features of this product work correctly. In use, the vehicle operator should ensure the projection of the warning signal is not blocked by vehicle components (i.e., open trunks or compartment doors), people, vehicles, or other obstructions.
7. The use of this or any other warning device does not ensure all drivers can or will observe or react to a warning signal. Never take the right-of-way for granted. It is your responsibility to be sure you can proceed safely before entering an intersection, driving against traffic, responding at a high rate of speed, walking on or around traffic lanes.
8. This equipment is intended for use by authorized personnel only. The user is responsible for understanding and obeying all laws regarding warning signal devices. Therefore, the user should check all applicable city, state, and federal laws and regulations. The manufacturer assumes no liability for any loss resulting from the use of this warning device.

Specifications:

EW300X

Peak current draw: 1.7A @ 12VDC

Max power: 23.2W @ 12VDC

EW301X

Peak current draw: 2.7A @ 12VDC

Max power: 37.5W @ 12VDC

Installation & Mounting:

Carefully remove the unit from its packaging. Examine the unit for transit damage. If damage is found, return the product to your local dealer for warranty replacement. Do not use damaged or broken parts.

Caution! When drilling into any vehicle surface, make sure that the area is free from any electrical wires, fuel lines, vehicle upholstery, etc. that could be damaged.

Notes:

1. Larger wires and tight connections will provide longer service life for components. For high current wires, it is recommended that terminal blocks or soldered connections be used with shrink tubing to protect the connections. Do not use insulation displacement connectors (e.g., 3M Scotchlock type connectors).
2. Route wiring using grommets and sealant when passing through compartment walls. Minimize the number of splices to reduce voltage drop. High ambient temperatures (e.g., under-hood) will significantly reduce the current carrying capacity of wires, fuses and circuit breakers. All wiring should conform to the minimum wire size and other recommendations of the manufacturer and be protected from moving parts and hot surfaces. Looms, grommets, cable ties and similar installation hardware should be used to anchor and protect all wiring.
3. Fuses or circuit breakers should be located as close to the power takeoff points as possible and properly sized to protect the wiring and devices.
4. Particular attention should be paid to the location and method of making electrical connections and splices to protect these points from corrosion and loss of conductivity.
5. Ground termination should be only made to substantial chassis components, preferably directly to the vehicle battery.
6. Circuit breakers are very sensitive to high temperatures and will "false trip" when mounted in hot environments or operated close to their capacity.

Permanent Mounting:

Mount the light so the wire exit on the base is facing the front of the vehicle. When the light returns to the default position, the lens is facing the rear.(EW301X)

1. Select a level surface for installation.
2. Drill mounting holes using the base as a template and attach with included hardware.

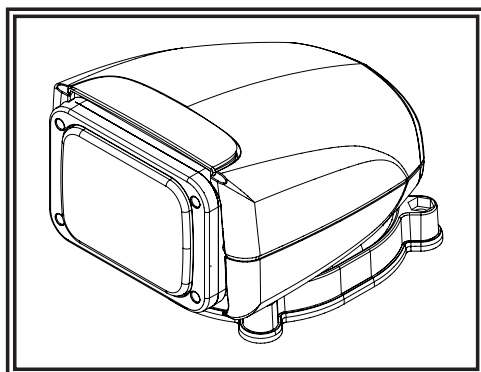

EW300X

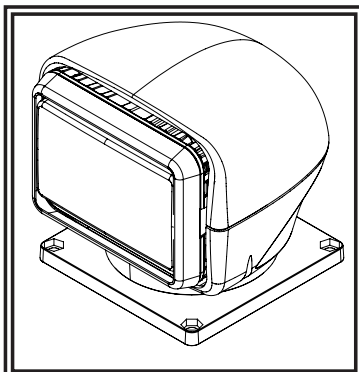

EW301X

Wiring:

Important! Disable power before wiring the product.

The wiring for this configuration is as shown in Figure 1 below. All wiring should be a minimum of 18AWG. The positive line must have a 5 amp fuse, as shown. Routing the ground wire directly back to negative battery terminal is recommended. Pack dielectric grease, such as Dow Corning 4, around each electric connection exposed to moisture or the ambient environment.

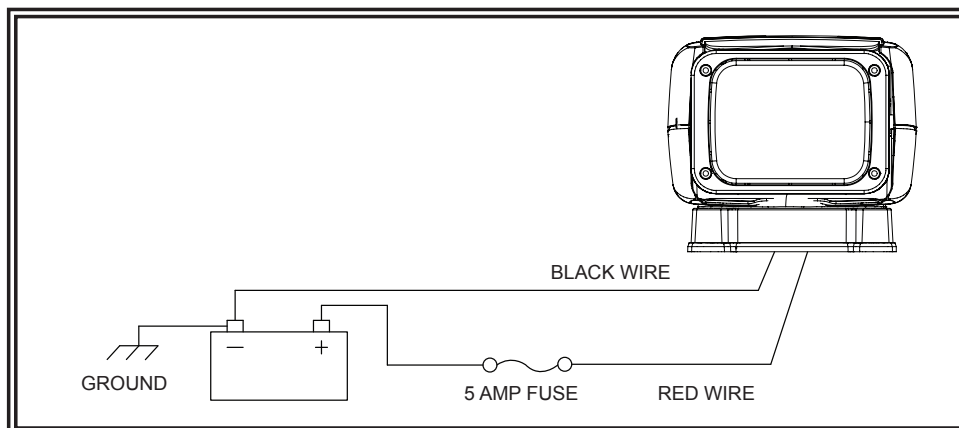
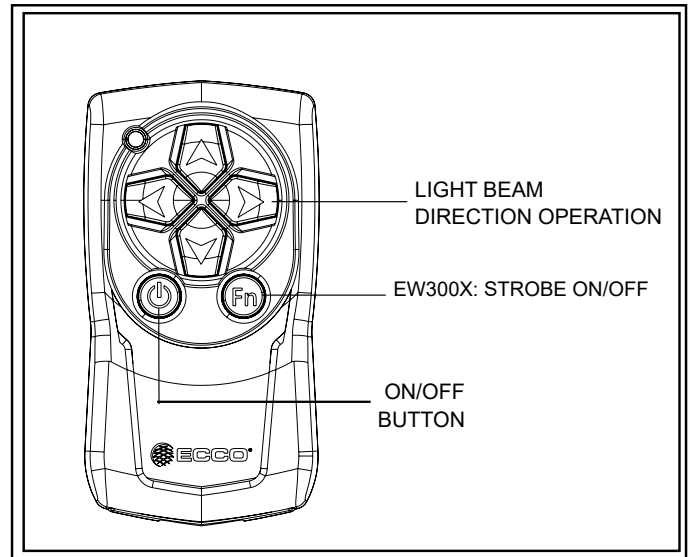

Figure 1

Remote Control Operation for EW300X:

Wireless Remote: Pairing and Programming

1. All remotes operate at 433.92MHz. Operating more than one wireless remote in close range will cause interference with other units if paired incorrectly.
2. Power off the spotlight by removing the fuse or disconnecting from main power. Install the fuse or reconnect to main power, then press the ▲ and ▼ buttons simultaneously within 5 seconds.
3. When programming is successful, the spotlight will flash 1 to 4 times. Each flash represents which memory slot the wireless remote is programmed to.
4. One wireless remote can be programmed to 4 spotlights. The spotlight will remember up to 4 wireless remotes.
5. To program more than one remote, follow existing steps to pair remote within initial 5 seconds of power up.
6. Each unit can be controlled by a single remote if the single remote is paired through all four channels as directed above. This means one vehicle can control up to 4 spotlights with four different remotes.
7. The optional in-dash controller will override the wireless remote.
8. In open air with full powered 23A batteries, the wireless remote will have a 65M range.



Remote Control Operation for EW301X:

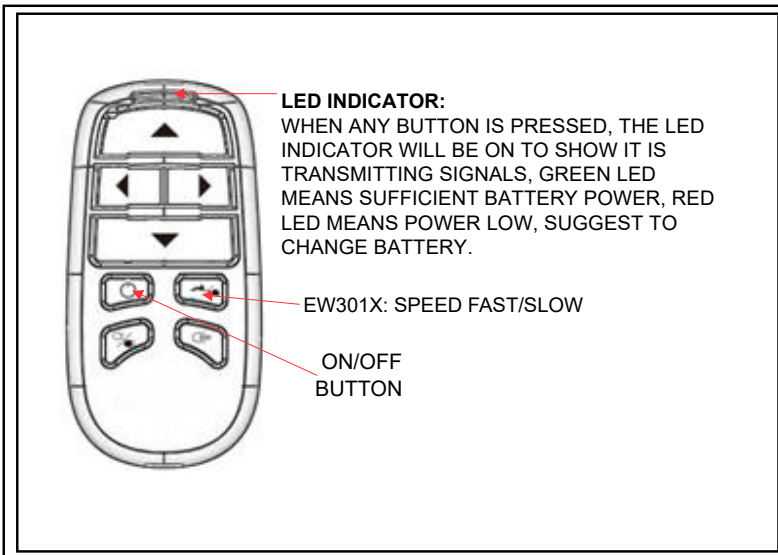

Button Functions:

(All buttons have LED back light, when pressed, the LED back light will light up)

1. Directions: ▲ Up, ▼ Down, ◀ Left, ▶ Right

Use the direction buttons to rotate or tilt the light.

2.  Main Power:

Press power button once, power will be on, the light is able to rotate or tilt (LED will not be on), press one more time, power will be off, the light will rotate to the back and tilt all the way down (return to home position).

3.  Fast/Slow:

Using this button to switch movement speed.

4.  LED on/off:

When main power is on, the LED light can be turned on or off using this button.

5.  Strobe:

When LED light is on, using this button to let LED flash as warning signal.

NOTE: The light beam direction is adjustable while the spotlight is off.

Joystick Control Operation for EW301X:

● Wired Dash Mount Joystick Control

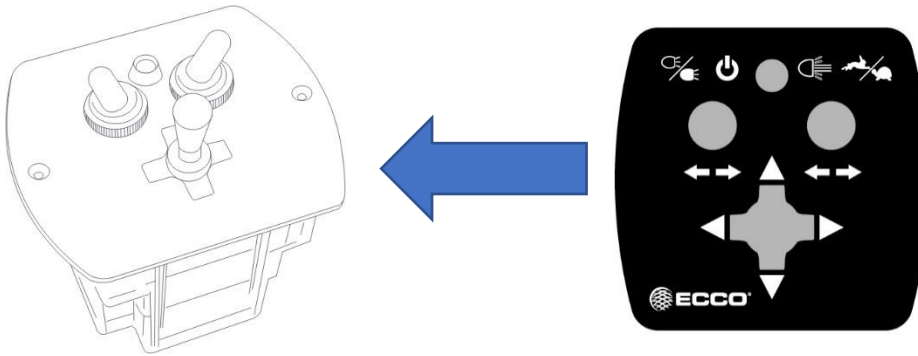

LED Power Indicator:

This LED power indicator will be steady on when main power is on to show the light is power on and is able to rotate or tilt.

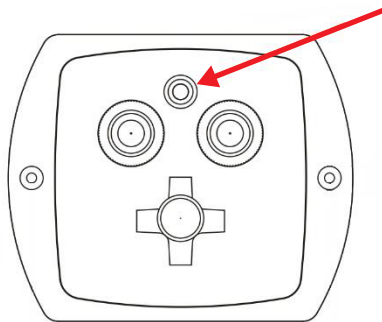

NOTE: The light beam direction is adjustable while the spotlight is off.

Joystick Functions:

1. Directions: ▲ Up, ▼ Down, ◀ Left, ▶ Right

Switch the joystick to above directions to rotate or tilt the light.

2.  Main Power:

Push the switch to the icon once, power will be on, the light is able to rotate or tilt (LED will not be on), press one more time, power will be off, the light will rotate to the back and tilt all the way down (return to home position).

3.  Fast/Slow:

Push the switch to the icon to switch movement speed.

4.  LED on/off:

When main power is on, the LED light can be turned on or off by pushing the switch to the icon.

5.  Strobe:

When LED light is on, push the switch to the icon to flash the LED as warning signal.

Replacement Parts and Accessories:

Description	Part No.
Replacement Remote (For use with EW3000 & EW3001)	ER3010
Replacement Remote (For use with EW3010 & EW3011)	ER3011
Flood Diffuser (For use with EW3010/11)	EZ3010F
Colored Lens (For use with EW3010/11)	EZ3010X*
In-Dash Joystick Controller (For use with EW3010/11, 6 Function)	EZ3011
5 Meter Joystick Cable (For use with EZ3011)	EZ3012
5 Meter Joystick Cable Extension (For use with EZ3011)	EZ3013
Magnet Mount Kit, Black (For use with EW3000)	EZ3014
Magnet Mount Kit, White (For use with EW3001)	EZ3015
Magnet Mount Kit, White (For use with EW3011)	EZ3016
Magnet Mount Kit, Black (For use with EW3010)	EZ3017
In-Dash Joystick Controller (For use with EW3010/11, 8 Function)	EZ3018
Adapter Bracket (For installing EW3010 or EW3011 on vehicles previously equipped with Go-Light spotlights)	EZ3010-ADPT

Where X* indicates color: A=Amber, R=Red and G=Green



This device complies with Part 15 of the FCC Rules. Operation is subject to the following two conditions: (1) this device may not cause harmful interference, and (2) this device must accept any interference received, including interference that may cause undesired operation

Electronics Controls Company "ECCO" (Manufacturer)

ECCO warrants that on the date of purchase, this product will conform to ECCO's specifications for this product (which are available from ECCO upon request). This Limited Warranty extends for sixty (60) months from the date of purchase.

DAMAGE TO PARTS OR PRODUCTS RESULTING FROM TAMPERING, ACCIDENT, ABUSE, MISUSE, NEGLIGENCE, UN-APPROVED MODIFICATIONS, FIRE OR OTHER HAZARD; IMPROPER INSTALLATION OR OPERATION; OR NOT BEING MAINTAINED IN ACCORDANCE WITH THE MAINTENANCE PROCEDURES SET FORTH IN ECCO'S INSTALLATION AND OPERATING INSTRUCTIONS VOIDS THIS LIMITED WARRANTY.

Exclusion of Other Warranties:

ECCO MAKES NO OTHER WARRANTIES, EXPRESSED OR IMPLIED. THE IMPLIED WARRANTIES FOR MERCHANTABILITY, QUALITY OR FITNESS FOR A PARTICULAR PURPOSE, OR ARISING FROM A COURSE OF DEALING, USAGE OR TRADE PRACTICE ARE HEREBY EXCLUDED AND SHALL NOT APPLY TO THE PRODUCT AND ARE HEREBY DISCLAIMED, EXCEPT TO THE EXTENT PROHIBITED BY APPLICABLE LAW. ORAL STATEMENTS OR REPRESENTATIONS ABOUT THE PRODUCT DO NOT CONSTITUTE WARRANTIES.

Remedies and Limitation of Liability:

ECCO'S SOLE LIABILITY AND BUYER'S EXCLUSIVE REMEDY IN CONTRACT, TORT (INCLUDING NEGLIGENCE), OR UNDER ANY OTHER THEORY AGAINST ECCO REGARDING THE PRODUCT AND ITS USE SHALL BE, AT ECCO'S DISCRETION, THE REPLACEMENT OR REPAIR OF THE PRODUCT, OR THE REFUND OF THE PURCHASE PRICE PAID BY BUYER FOR NON-CONFORMING PRODUCT. IN NO EVENT SHALL ECCO'S LIABILITY ARISING OUT OF THIS LIMITED WARRANTY OR ANY OTHER CLAIM RELATED TO THE ECCO'S PRODUCTS EXCEED THE AMOUNT PAID FOR THE PRODUCT BY BUYER AT THE TIME OF THE ORIGINAL PURCHASE. IN NO EVENT SHALL ECCO BE LIABLE FOR LOST PROFITS, THE COST OF SUBSTITUTE EQUIPMENT OR LABOR, PROPERTY DAMAGE, OR OTHER SPECIAL, CONSEQUENTIAL, OR INCIDENTAL DAMAGES BASED UPON ANY CLAIM FOR BREACH OF CONTRACT, IMPROPER INSTALLATION, NEGLIGENCE, OR OTHER CLAIM, EVEN IF ECCO OR A REPRESENTATIVE OF ECCO HAS BEEN ADVISED OF THE POSSIBILITY OF SUCH DAMAGES. ECCO SHALL HAVE NO FURTHER OBLIGATION OR LIABILITY WITH RESPECT TO THE PRODUCT OR ITS SALE, OPERATION AND USE, AND ECCO NEITHER ASSUMES NOR AUTHORIZES THE ASSUMPTION OF ANY OTHER OBLIGATION OR LIABILITY IN CONNECTION WITH SUCH PRODUCT.

This Limited Warranty defines specific legal rights. You may have other legal rights which vary from jurisdiction to jurisdiction. Some jurisdictions do not allow the exclusion or limitation of incidental or consequential damages.



833 West Diamond St
Boise, Idaho 83705

Customer Service

USA 800-635-5900

UK +44 (0)113 237 5340

AUS +61 (0)3 63322444

ECCOESG.com

An ECCO SAFETY GROUP™ Brand
www.eccosafetygroup.com