

REVISION HISTORY		
REV.	DESCRIPTION	DATE
03	REVISED PER EL0170	2019-08-27
A	INITIAL RELEASE PER EL0170	2019-09-10
B	REVISED PER EL0170	2019-11-18

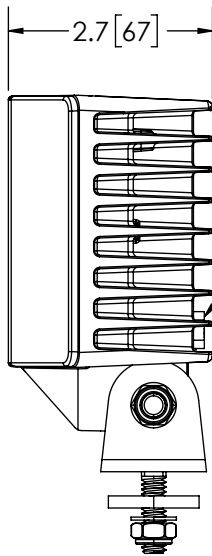
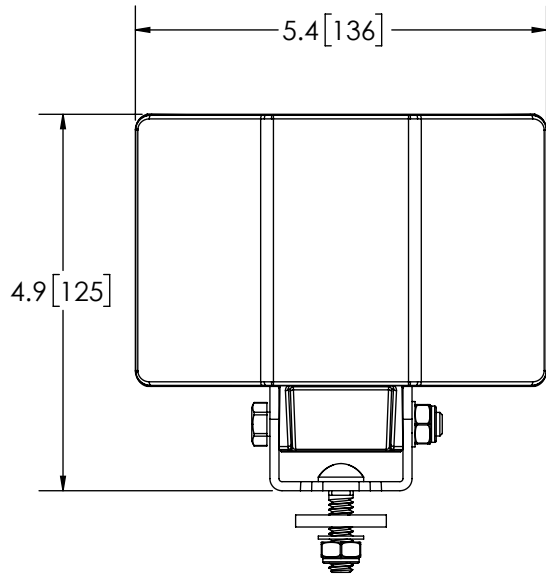

BUILT-IN CONNECTOR
 HOUSING: DEUTSCH P/N DT04-2P
 TERMINALS: DEUTSCH P/N 1060-16-0122
 WEDGE LOCK: DEUTSCH PN W2P
 PIN 1: POSITIVE (+)
 PIN 2: NEGATIVE(-)

SPECIFICATIONS

- CERTIFICATIONS: ECE R10; ; IP67; CISPR25
 Note: Unique components, accessories, and hardware kits are not typically included in the Product Certification Test Protocols. Unless otherwise Specified, the Product Certifications referred to herein are predicated upon the base product model configuration.
- RAW LUMENS: 3742 lumens
- EFFECTIVE LUMENS: 3074 lumens
- ILLUMINANCE (@100 FT): 6.1 lux
- PEAK BEAM INTENSITY: 5619 candela
- VOLTAGE (NOMINAL): 12-24 VDC
- VOLTAGE (EXTREME): 10-30 VDC
- CURRENT (PEAK): 3.64A (@ 12 VDC NOMINAL)
- POWER (MAXIMUM): 46.6W (@ 12 VDC NOMINAL)
- TEMPERATURE RANGE: -40°F (-40°C) TO 149°F (65°C)
- CONNECTION: DEUTSCH CONNECTOR
- MOUNTING: BRACKET MOUNT
- HOUSING MATERIAL: ALUMINUM
- LENS MATERIAL: POLYCARBONATE
- PRODUCT WEIGHT: 1.9 LBS (0.86 Kg)

DISCLAIMER
 DIMENSIONS, ILLUSTRATIONS, SPECIFICATIONS, AND CERTIFICATIONS CONTAINED IN THIS DOCUMENT ARE TYPICAL OF THE ACTUAL PRODUCT AND ARE SUBJECT TO CHANGE. ECCO ENGINEERING DOES NOT MAINTAIN FORMAL DESIGN CONTROL OF THIS PRODUCT.

- NOTES:**
- ROHS COMPLIANT
 - DIMENSIONS IN INCHES[MILLIMETERS (FOR REFERENCE)]

SCALE 1:2.5		APPROVALS	DATE	ECCO [®] www.eccolink.com Americas (800) 635-5900 Europe +44 (0)113 237 5340 Asia Pacific +61 (0)3 63322444				
CAD GENERATED DRAWING DO NOT MANUALLY UPDATE. MODEL REFERENCED: 01		DRAWN BY ABD	2019-11-12					
TOLERANCES ARE IN INCHES, AND MILLIMETERS TOLERANCES UNLESS OTHERWISE STATED ARE:		CHECKED ABB	2019-11-13	WORKLAMP, 6 LED, SQUARE, 120* FLOOD, 12-24V				
MILLIMETERS DECIMALS XX. ± 1.0mm XX.X ± 0.5mm	INCHES DECIMALS X.X ± 0.1 X.XX ± 0.04 X.XXX ± 0.02	MECH. ENG.			CUSTOMER PART NO. EW2530			
<table border="1"> <tr> <th>ANGLES</th> <th>FRACTIONS</th> </tr> <tr> <td>± 0.5°</td> <td>± 1/64</td> </tr> </table>		ANGLES	FRACTIONS	± 0.5°	± 1/64	ELEC. ENG. TM	2019-11-12	PRODUCT SERIES: EW2500
ANGLES	FRACTIONS							
± 0.5°	± 1/64							
THIRD ANGLE PROJECTION		TEST ENG. RM	2019-11-14	SIZE: A				
		SALES. ARS	2019-11-13	DWG. NO. EW2530				
		Electronically Controlled Use Latest Copy		REV. B				
		SHEET 1 OF 1		Date Created: 2019-07-29				

PROPRIETARY AND CONFIDENTIAL INFORMATION
 THIS DRAWING AND THE DESIGN AND OTHER INFORMATION DISCLOSED HEREIN ARE THE PROPERTY OF ELECTRONIC CONTROLS COMPANY AND/OR ITS ECCO SAFETY GROUP AFFILIATES ("ECCO") AND IS ISSUED IN CONFIDENCE TO RECIPIENT FOR ENGINEERING INFORMATION PURPOSES ONLY. THIS DRAWING AND THE DESIGN AND OTHER INFORMATION DISCLOSED HEREIN MAY NOT BE USED, COPIED, REPRODUCED OR OTHERWISE DISCLOSED IN PART OR IN WHOLE TO THIRD PARTIES OR USED FOR ANY OTHER PURPOSE WITHOUT PRIOR ECCO WRITTEN CONSENT. ECCO RESERVES ALL PATENT, COPYRIGHT, TRADEMARK AND OTHER PROPRIETARY RIGHTS TO THIS DOCUMENT, INCLUDING ALL DESIGN, MANUFACTURING, REPRODUCTION, USE AND SALES RIGHTS THERETO. THIS DRAWING IS SUBJECT TO RECALL BY ECCO AT ANY TIME, AND YOUR POSSESSION AND/OR USE CONSTITUTES ACCEPTANCE OF THESE TERMS. ©2019 ELECTRONIC CONTROLS COMPANY